

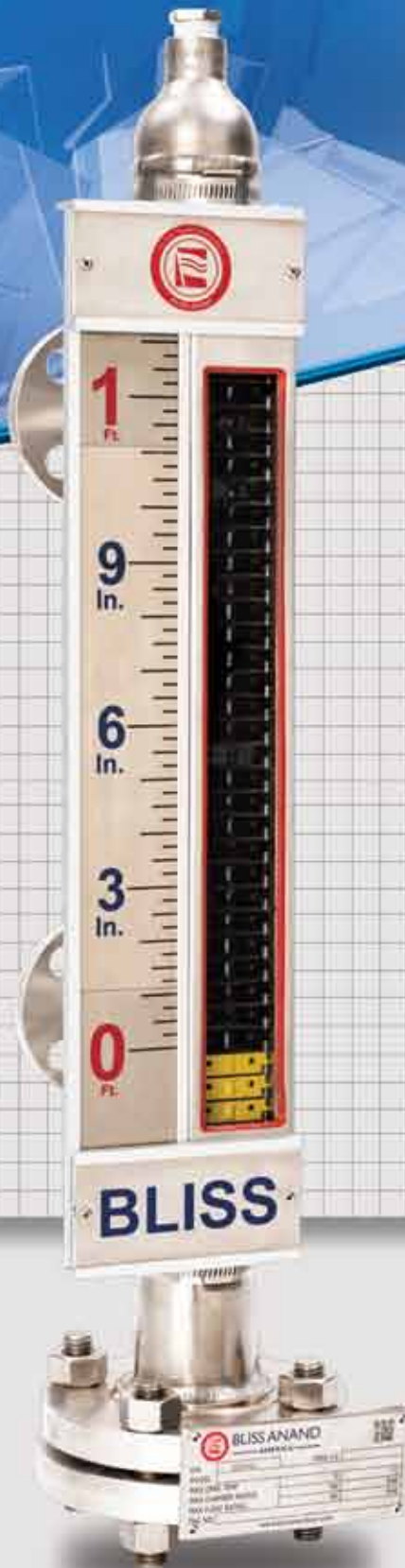

BLISS ANAND

BAM Series Magnetic Level Gauge



BAM Series Magnetic Level Gauge



Index:

Superior Level Indicator	03
Principle of Operation	05
Typical Mounting Styles	06
Typical Installations	07
Selection Guide - BAM 92 Series	08 - 09
Selection of MLG	10
Indicators	11 - 14
Float	15 - 16
Magnetostrictive Type Level Sensor	17 - 18
Accessories	19 - 21
Special Requirements & Testing	22
Engineering Standards	23



MAGNETIC LEVEL GAUGE





SUPERIOR LEVEL INDICATOR

SUPERIOR LEVEL INDICATOR

Bliss Anand magnetic level gauges are highly accurate, low-maintenance alternatives to sight glasses and other outdated level indicators. They provide redundant, non-invasive level indication while eliminating leak points and fugitive emissions. Their robust design is ideal for high temperatures, high pressures and corrosive services. Bliss Anand gauges are easy to install and require no additional piping in most applications.

Combined with externally mounted transmitters and switches, Bliss Anand magnetic level gauges provide the industry's most advanced and cost-effective level solutions.

FEATURES

- Level indication viewable up to 150 feet away
- No process liquid in contact with indicator glass
- Ideal for high-temperature, high-pressure and corrosive applications
- Manufactured to meet ASME B31.1/B31.3 or PED 97/23 as specified
- Magnetostrictive and radar transmitter options for non-invasive and/or redundant level control
- Float failure indication (Standard)
- All external parts SS316 or as specified
- 360° magnetic coupling
- Full corrosion resistance system
- Measurement is unaffected by pressure, vacuum, temperature, foam and viscosity at design condition
- Minimum sensitivity to density variation
- Permanent local indication without external power supply
- Optional adjustable alarm switches
- Safe, environment friendly and trouble-free design
- Indicating assembly certified to IP-66



APPLICATIONS

- Feedwater heaters
- Industrial boilers
- Oil/water separators
- Flash drums
- Surge tanks
- Gas chillers
- Deaerators
- Blowdown flash tanks
- Hot wells
- Vacuum tower bottoms
- Alkylation units
- Boiler drums
- Propane vessels
- Storage tanks



MAGNETIC LEVEL GAUGE

SAFETY FIRST

Code Welding:

- Full bore / full penetration welds
- Stronger weld joints
- Per ASME codes and NACE MR-01-75
- Unique & Reliable (Life Time Warranty)

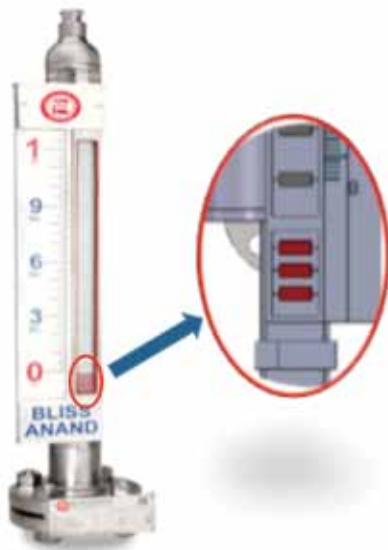
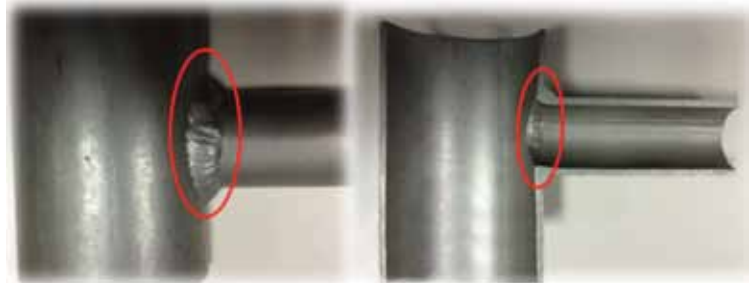

Standard Float Failure Indication (Plant Safety):

- Provided as standard
- Immediate indication in case of failure of float
- Ensures plant safety

Flashing Application

- Oversized chamber
- Guide rods design to allow vapors to pass through the vacant area
- Throttle design on request

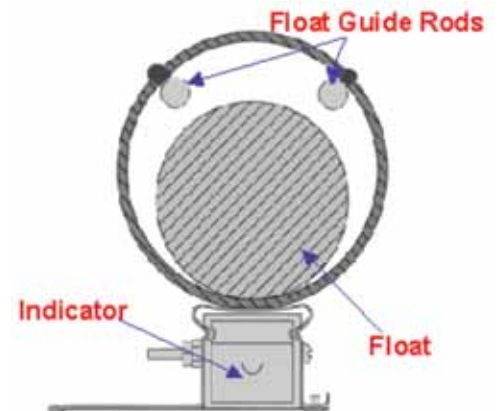



PRINCIPLE OF OPERATION

PRINCIPLE OF OPERATION

Bliss Anand magnetic level gauges consist of a float chamber with process connections suitable for installation to the vessel. The process connections may be side couplings, flanges or other configurations as illustrated on the following page.

The magnetic bar graph indicator is externally mounted to the float chamber; therefore, it is not a wetted part and is isolated from the process. Flipper-style indicators are standard with bright, contrasting colours for clear and concise level indication.

The bar graph indicators are operated by the custom float installed in the chamber. Contained within the float is a 360° magnet assembly, which operates the external bar graph indicators through the chamber pipe wall. Floats are designed to meet the application process specific gravity and pressure, and are sized accordingly.

As the float rises and falls with the process level, the magnet drives the external bar graph assembly, providing local indication to the operator, or providing the magnetic coupling for transmitter output.

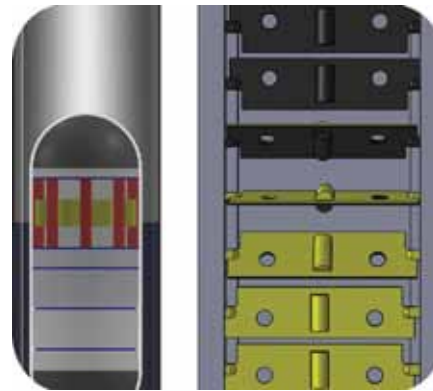

SPECIFICATION

All Bliss Anand liquid level gauges are custom-engineered and manufactured based on customer application and specifications. The table below lists minimum standard materials, design, testing and other options as required by the application.

	Typical Construction	Optional (as per requirement)
Chamber Material	316 Series stainless wetted parts	Other non-ferrous materials that do not exhibit ferromagnetic properties such as Hastelloy, CB20, Inconel, Monel 400 and T-321 stainless
Chamber Pipe	2" S40 seamless pipe depending upon the application pressure, temperature and corrosion allowance	2", 2½", 3" may be required, schedules up to 160 depending upon application requirements
Chamber Flanges	As per customer specifications	ANSI weld neck style, socket weld, or lap joint, and other flange faces such as RTJ or flat face
Process Connections	As per customer specifications or socket weld connections	ANSI weld neck style, socket weld, or lap joint, and other size or rating NPT
Float Assembly	Titanium STD. Others available per application: -320°F to 1000°F, SG 0.38, pressure from vacuum to 3000psi	Bliss Anand offers floats in Hastelloy, Monel and 316SS, as required and rated up to 3000psi or as low as 0.35 minimum specific gravity
Indicator	Brightly coloured (as per requirement) SS316 high temperature design reading in feet and inches with ½" divisions; approximately ¼" resolution	Other indicator colours, units of measure or follower type may be specified
Chamber Design	Float chamber is designed to ANSI B31.3 and ASME boiler code PG60. Welding and welder qualification in accordance with ASME section IX	Welding procedures, qualifications or testing may be supplied if required, as well as designs to propriety customer design specifications
Testing	Functional and calibration test are performed on Bliss Anand gauges with magnetostrictive sensors	Additional testing and documentation such as MTR's, radiography, hydrostatic pressure tests, PMI, dye penetrant, NACE or witness testing are available as specified



MAGNETIC LEVEL GAUGE

TYPICAL MOUNTING STYLES

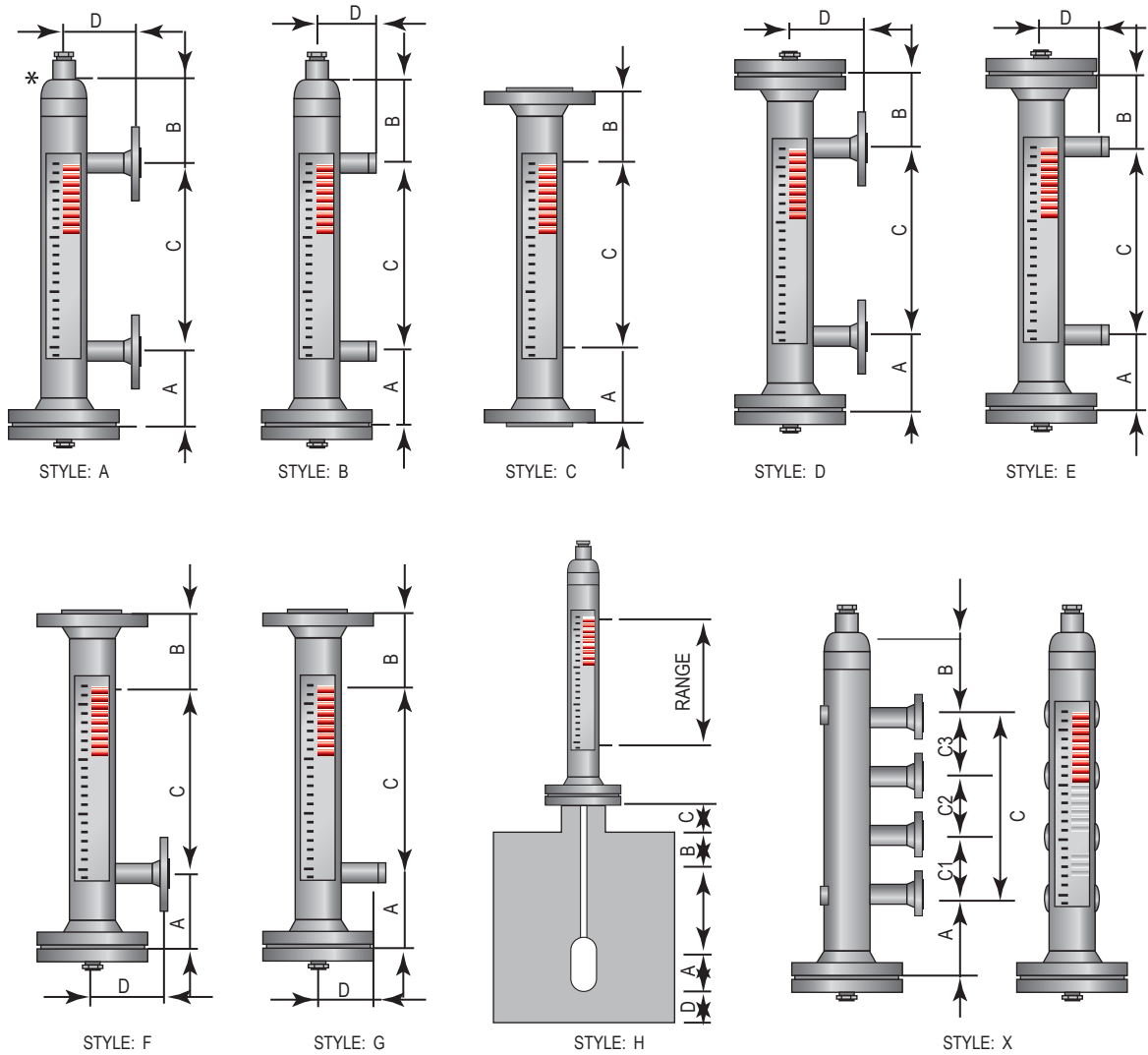

These are the standard configurations. For tailor made/ custom built configuration, please consult our sales department.

TYPICAL INSTALLATIONS

*

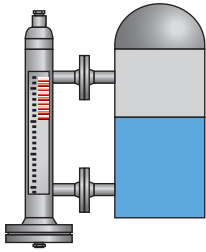

STYLE: A

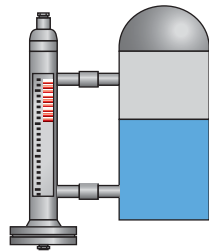

STYLE: B

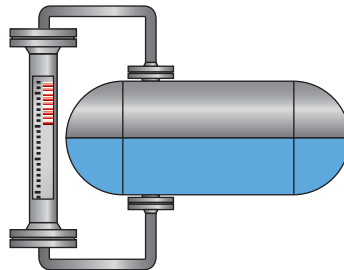

STYLE: C

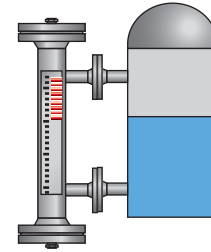

STYLE: D

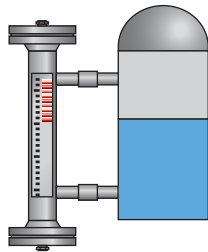

STYLE: E

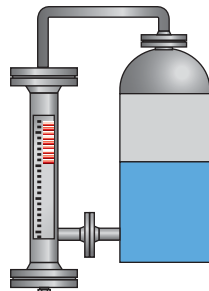

STYLE: F

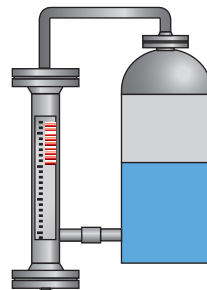

STYLE: G

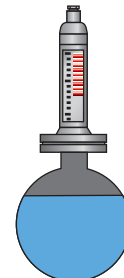

STYLE: H

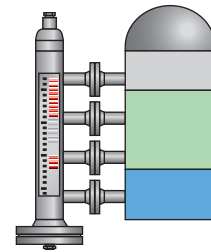

STYLE: X

* Most Common

Bliss provides engineering solutions for all types of vessel connections. These are the Bliss standard configurations. For customized designs please consult our sales department.

MAGNETIC LEVEL GAUGE SELECTION GUIDE - BAM 92 Series

Selection	Suffix Codes										Description	
A Orientation Style	A											Side-Side Flanged
	B											Side-Side Screwed
	C											Top & Bottom
	D											Side-Side with Top Flanged
	E											Side-Side Screwed with Top Flanged
	F											Top & Side Flanged
	G											Top & Side Screwed
	H											Top Mounted
	X											Special
	B Chamber Material	S1										
S2												316 SS
8N												Inconel 852
6N												Inconel 625
HA												Hastelloy-C 276
KY												PVDF
PP												Polypropylene
PV												PVC/CPVC
XX											Special	
C Float Material	S2											SS-316 / 316L
	TI											Titanium
	PV											PVC/CPVC
	PP											Polypropylene
	KY											PVDF
	HA											Hastelloy
	XX											Special
D Process Connection Type	F											Flanged
	S											Screwed
	W											Welded
	X											Special
E Process Connection Size	1											1/2"
	2											3/4"
	3											1"
	4											1 1/2"
	5											2"
	6											2.5"
	7											3"
	8											4" (Only Top Mounted)
F Process Connection Rating	A											150#
	B											300#
	C											600#
	D											900#
	E											1500#
	F											2500#
	T											NPT(F) - 3000#
	X											Special
G Process Connection Finish	TH											Threaded
	RF											RF
	WN											WNRF
	WJ											WNRTJ
	SJ											SORTJ
	XX											Special
H Indicator Type	F											Flipper (Wide/Standard option)
	S											Shuttle
I Indicator Construction	AL											Aluminium Enclosure With AL. Flap
	SS											St. Steel Enclosure With SS Flap
	XX											Special
J Scale	OO											No Scale
	SM											St. Steel in mm
	SI											St. Steel in Inches
	XX											Special

MAGNETIC LEVEL GAUGE SELECTION GUIDE - BAM 92 Series

Selection		Suffix Codes												Description					
K	Vent Connection													PL					Plugged
															FL				Flanged
															FV				Flanged with Valve
															SV				Screwed with Valve
															XX				Special
L	Vent Connection Size													1				1/2"	
														2				3/4"	
														3				1"	
														X				Special (Specify)	
M	Vent Connection Rating													A				150#	
														B				300#	
														C				600#	
														D				900#	
														E				1500#	
														F				2500#	
														T				NPT(F) - 3000#	
												X				Special (Specify)			
N	Vent Connection Type													TH				Threaded	
														RF				RF	
														WN				WNRF	
														SJ				SORTJ	
														WJ				WNRTJ	
												XX					Special (Specify)		
O	Drain Connection													PL				Plugged	
														FL				Flanged	
														FV				Flanged with Valve	
														SV				Screwed with Valve	
														XX				Special	
P	Drain Connection Size													1				1/2"	
														2				3/4"	
														3				1"	
														X				Special (Specify)	
Q	Drain Connection Rating													A				150#	
														B				300#	
														C				600#	
														D				900#	
														E				1500#	
														F				2500#	
														T				NPT(F) - 3000#	
												X				Special (Specify)			
R	Drain Connection Type													TH				Threaded	
														RF				RF	
														WN				WNRF	
														SJ				SORTJ	
														WJ				WNRTJ	
												XX					Special (Specify)		
S	Options & Specials													OO				No Optional Accessories	
														HT				Heat Tracing (External)	
														MX				Magnetostrictive sensor	
														SW				Point Switch (SPDT Reed)	
														IN				Insulation	
														FS				Frost Shield	
												CY				Cryogenic Application			
												XX					Special		
T	CC Distance																XXXX	Specify with unit	
U	Indicating Range																XXXX	Specify with unit	
V	Application																	L	Level
																		I	Interface
W	Liquid Density (Upper)																X.XX	To Specify	
X	Liquid Density (Lower)																X.XX	To Specify	



MAGNETIC LEVEL GAUGE

SELECTION OF MLG

Selecting the appropriate MLG for a specific application is important. Review your requirements and establish a set of criteria for selecting the right MLG for the application. This guide provides key information about the components of an MLG to help you make informed decisions.

What is the process fluid?

- Specific gravity
- Operating temperature
- Operating pressure
- Interface or full-level detection

What are the gauge body details?

- Material of construction
- Maximum pressure requirement
- Necessary level range (center - center distance) (fluid fluctuation - often the vessel height)
- Vent and drain connections

What are the process connection details?

- Size
- Type
- Rating
- Orientation/position

What type of indicator is preferred?

- Flag (red/ white, yellow/ black, other)
- Shuttle

What measuring scale is required?

- Level (inches, feet, meters)
- Volume (gallons, liters, custom)
- Percent & mm, % & m, % & cm, etc.

What accessories are necessary?

- Switch function and type
- Level transmitter
- Frost extension (required for cryogenic applications)
- Heat trace
- High or low-temp insulation
- Magnetic traps
- Gauge glass/Sight Glass

The following information is required to order or request a quotation for Magnetic level gauges. Use the following configuration guide to select the model number.

Required Information

1. Magnetic level gauge to be used for

- a. Level
- b. Interface

2. Service liquid, please specify

- a. Upper liquid & specific gravity
- b. Lower liquid & specific gravity

3. Operating pressure:

Maximum pressure:

4. Operating temperature:

Maximum temperature:

Minimum temperature:

Model No. Configuration

BAM92A/B/C/D/E/F/G/H/I/J/K/L/M/N/O/P/Q/R/S/T/U/V/W/X

SPECIAL APPLICATION

All gauge dimensions are nominal except "CL" or "measuring range". Standard chamber size is 2". Schedule 40 (Consult Factory).

INDICATORS

INDICATORS

The indicator visually displays the level measured by the float inside the column. It is located on the outside of the chamber as either a glass tube or a metal channel with a flat glass front. By magnetically coupling with the float, which follows the level of the fluid, it displays the fluid level. The indicator must be positioned close to the chamber so that the magnetic field of the float and the indicator can be coupled, but not too close that process conditions affect the indicator adversely. The chamber minimizes the effects of turbulent process conditions within the vessel that can adversely affect the float or indicator. Where process level is turbulent due to mixing, filling or emptying of the vessel, the chamber minimizes these actions, keeping the float from violent vertical movement and erratic indication.

TYPES OF INDICATORS

There are two main types of indicators – Shuttle and Flags.

I. Shuttle Indicators

The shuttle (bullet or follower) indicator consists of a follower with an imbedded magnet or piece of ferromagnetic material that moves freely in a glass column attached to the vessel. The glass column is isolated from the MLG chamber that contains the process fluid. When the fluid level in the vessel changes, the level in the attached chamber changes correspondingly. The shuttle is magnetically coupled to the magnet in the float. As the float rises and falls according to the fluid level, it drags the shuttle along with its magnetic field. The shuttle is brightly coloured so that it can be seen from afar.

The shuttle level indicator is often used to cut costs. However, in an interface application, where levels of two fluids are to be measured in one chamber, shuttle indicators are recommended. It provides a visual indication that is suitable for most applications, except when flashing or extreme turbulence occurs within the process vessel. To recalibrate, the shuttle must be reset by using an external magnet to recouple it to the magnetic field of the float.

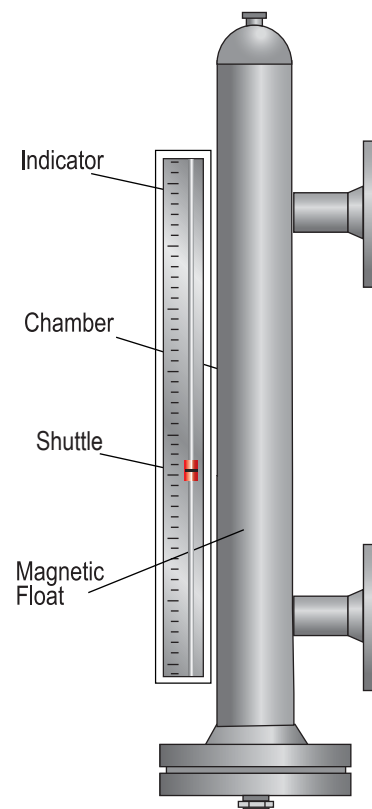

Indicator with Shuttle



MAGNETIC LEVEL GAUGE

INDICATORS

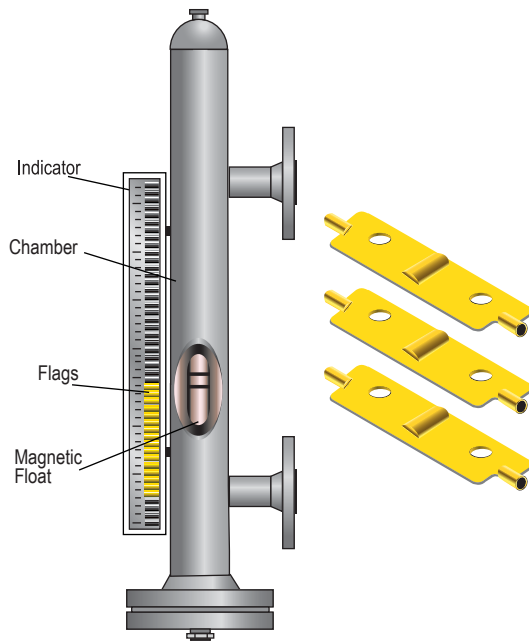

Indicator with Flags

II. Flag Indicators

The flag indicator gets its name from a system of small strips of material with contrasting colours on opposite sides. As the float moves up or down with the fluid level in the vessel, each flag rotates to display a colour that corresponds to its orientation with respect to the magnetic field of the float. The front of the flag indicates that the float magnet is above the flag, and the back shows that the float magnet is below the flag. Flags, also called flappers, contain a small magnet. The magnet may be an embedded vertical magnet(s) or a less expensive flexible magnet.

RIGHT SELECTION OF INDICATOR

When deciding whether to use a shuttle or a flag indicator for a specific application, consider the cost, durability, visibility and maintenance requirements. Usually a shuttle indicator is more cost-effective and can be adapted to show the overall liquid level and the fluid interface level on the same indicator. However, the flag indicator is easy to see from a distance, operates effectively at higher temperatures, and does not suffer from decoupling.

	Advantages
Shuttle	<ul style="list-style-type: none"> • Lower cost • Can show overall level and fluid interface level on same indicator using two shuttles
Flag	<ul style="list-style-type: none"> • Reduced risk of decoupling • Metal rail with flat glass front provides additional strength and security • Easy to read from greater distances • Metal flags allow operation at higher temperatures

BLISS ANAND INDICATORS

Bliss Anand MLGs are available with shuttle or flag indicators.

The shuttle in Bliss Anand indicators are brightly coloured (yellow and black) so they can be easily seen from a distance of 150 feet (46m). To reduce the occurrence of magnetic decoupling, the shuttles in Bliss Anand MLGs contain highly charged magnets, and the floats make use of a flux ring configuration, which enhances the floats magnetic field.

High quality, embedded vertical magnets are used in Bliss Anand flag indicators. The flags incorporate a locking mechanism to prevent accidental flipping due to vibration or other motions.

MAGNETIC LEVEL GAUGE



INDICATORS

Bliss Anand flags and pivot axes are always made of identical materials to prevent any binding that might result from different thermal expansion rates. Compared to plastic flags, metal flags are of better quality and are more reliable because metal-to-metal contact yields less pivot resistance, can withstand higher temperatures (up to +1000°F [+538°C]) and are more resistant to twisting or warping.

INDICATOR SEALING METHODS

MLG indicators may be sealed, unsealed or hermetically sealed. In some situations indicator with a sealed-valve may be the appropriate choice.

I. UNSEALED

Unsealed indicators are less expensive, but ambient conditions can affect or damage the indicator. Unsealed indicators should not be used outdoors or in a location where moisture or freezing temperatures may exist. Indicators with an unsealed column may accumulate moisture and freeze, restricting the movement of the shuttle or preventing the flags from rotating about their axes. In some environments, moisture or oxidation can cloud the glass of the indicator column and reduce visibility. Deposits may build up on the inside of the glass and block the view of the shuttle mark or the flag's flip point. In addition, foreign material or damage from ambient corrosives may impair the pivot action of the flags.

II. SEALED

Sealed indicators can be used indoors and outdoors with varying temperatures and moisture, as it won't accumulate moisture and freeze or prevent the flag from performing. Sealed indicators also won't be exposed to condensation or deposit build up.

III. HERMETICALLY SEALED

Hermetically sealed indicators have an evacuation valve at the bottom and top of the indicator that allows oxygen and moisture to be removed, and a low, positive pressure of inert gas to be inserted. The inert gas eliminates problems such as reduced visibility and responsiveness caused by oxidation. In addition, pressurization with an inert gas solves most flag sticking problems because moisture and debris in the column are eliminated.

RIGHT INDICATOR SEAL SELECTION

Cost and operating environment are two important considerations when deciding whether to use an unsealed, sealed or valve-sealed indicator. Although the unsealed column is the lowest cost option, it exposes the indicator to the surrounding environment. If cold temperatures, high moisture, or corrosive conditions are present, a sealed or valve-sealed indicator is the better choice.

	Advantages
Unsealed	<ul style="list-style-type: none">• Less expensive than sealed or valve-sealed
Sealed	<ul style="list-style-type: none">• Less expensive than valve-sealed• Glass clouding will be avoided in ordinary conditions
Hermetically Sealed	<ul style="list-style-type: none">• Oxygen is replaced with inert gas to reduce oxidation• Low positive pressure minimizes the presence of moisture



MAGNETIC LEVEL GAUGE

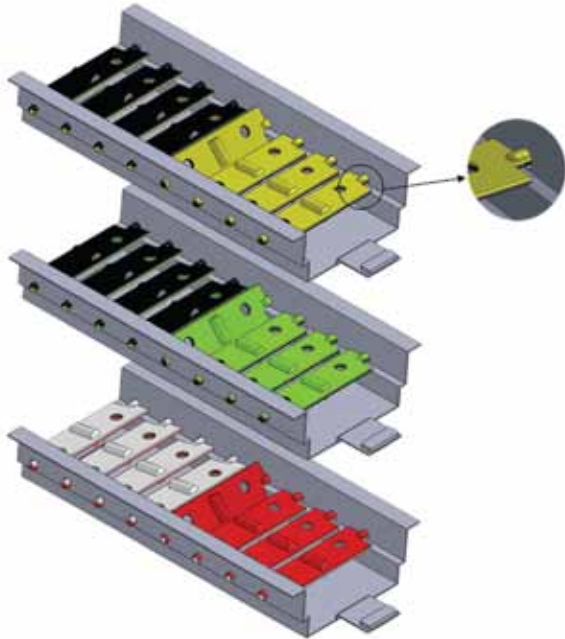

Bliss indicators incorporate an interlocking mechanism on the channel, to restrict flag rotation to 180°. Hence, providing accurate level indication irrespective of the process fluid velocity.

Bliss Anand Wide Track indicators provide better visibility from a further distance.

- Wide Track Indicator = WTI (optional)
- Standard Indicator = SI (Std.)
- IP66 certified

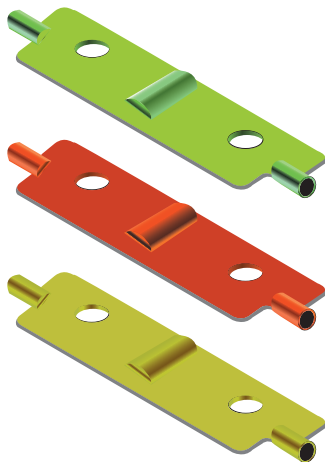

Custom coloured flag and shuttle indicators are made available as per order.

FLOAT

FLOAT

The float is a strong canister that is engineered for temperature and pressure conditions of an application and designed to operate in the specific gravity of the fluid to be measured. It consists of a system of magnet(s) that form a strong magnetic field. The float rises and falls with the level of the fluid.

In a standard configuration, the float's magnet(s) is coupled with the indicator's magnets, mounted on the outside of the chamber, indicating the fluid level inside the vessel.

Since the indicator is externally mounted, it is isolated from the process conditions. Thus providing long-lasting and error-free operation of the MLG.

The coupling between the float and the indicator differs in a side and a top-mounted orientation. The side-mounted orientation works on the basis of the standard design. In a top-mounted orientation, the float is located inside the vessel (within a guide pipe), without a magnet assembly. Instead, it is mechanically connected by a rod to a magnet in a chamber on top of the vessel. As the float rises and falls within the guide pipe, the magnet attached to the top of the rod gets coupled with the indicator mounted on the outside of the chamber displaying the fluid level.

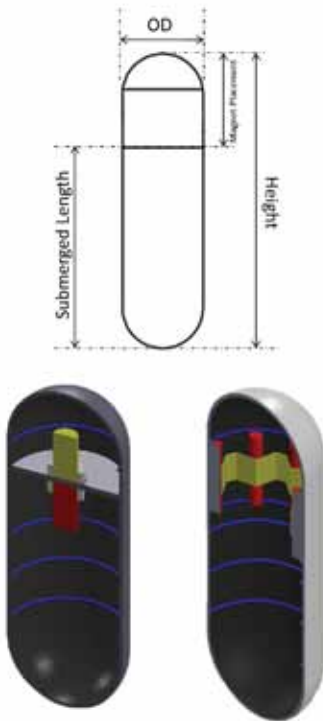

RIGHT FLOAT SELECTION

Our floats are designed to function at the highest temperature pressure of the process fluid, to ensure accurate readings of the application specific gravity.

If the specific gravity of the process fluid varies, it is necessary to calibrate the float for the minimum specific gravity and calculate the variance in float levels to determine the level-measurement error.

The materials and design chosen for a float depends on cost, the process conditions and media properties, such as density/specific gravity, temperature, pressure and corrosiveness. Many MLGs are installed in extreme environments so the materials and design of the float can affect level indication performance.

BLISS ANAND FLOATS

Bliss Anand floats are made from a wide range of strong alloys including stainless steel, titanium, Hastelloy C-276, Inconel, Alloy 20, fiberglass and various durable plastics. Material of the float is selected according to the temperature range and corrosiveness of the process fluid. The metallic floats are precision welded by a pulse TIG or electron beam process. Specific gravity and serial number data are engraved onto every float to ensure identification. Floats may be TFE coated for corrosive applications.



MAGNETIC LEVEL GAUGE

FLOAT

Bliss Anand floats feature a retainer ring that precisely aligns the vertical magnets. The 360° vertical placement of the magnets ensures proper magnetic coupling with the flag or shuttle of the indicator, even as the float turns within the chamber. A flux ring guarantees a constant, long-lasting, gauss rating even at temperatures of +1000° F (+538° C).

FLOAT CURVE

The float rides with the magnet ring at the liquid surface, and about 2/3 (80%) or more of the float is submerged. The amount of submergence, and the buoyancy safety factor vary with S.G., as you can see from the float curve below. Bliss Anand floats are typically designed for a buoyancy safety factor of 75 grams (2.6 Oz) to ensure reliability. Buoyancy can be determined using Archimedes principal. (S.G. x submerged float volume in CC) – float weight in grams. A sufficient buoyancy safety factor helps ensure reliability despite friction or light build up that may occur under some conditions.

“Float curve shall be provided on request. Please contact our facility for further information.”

PRESSURE AND TEMPERATURE

Magnetic Level Gauges are available for a working pressure of 241bar (3500psi) and a maximum temperature of 538°C (1000°F). For higher pressure, temperature & customized specifications, please consult factory.



MAGNETOSTRICTIVE TYPE LEVEL SENSOR

MAGNETOSTRICTIVE TYPE LEVEL SENSOR

Magnetostrictive Level Sensors are used for continuous liquid and interface level indication. This measuring process is the magnetostrictive principle.

It is initiated by a current pulse, which generates an axial magnetic field along the length of a wire made of magnetostrictive material, which is held under tension inside the guide tube. The float, which sits on the liquid surface, is fitted with permanent magnets. When the pulse reaches the float the two magnetic fields interact and creates a torsional force in the wire. This torsional force is converted into an electrical signal by a piezoceramic converter in the transmitter housing. By measuring the elapsed transit time, it is possible to determine the start point of the torsional stress wave and therefore the float position with a high degree of accuracy.

STANDARD SPECIFICATIONS

1. Operations : By the float magnet of the magnetic level gauge inside the chamber
2. Protection : a) EEx is intrinsic safely IP 68
b) EExd explosion proof feature-IP 68
3. Accuracy : $\pm 0.05\%$ of span (± 2 mm min)
4. Measuring Range : 9m maximum
5. Supply : 12 to 36 V dc
6. Output : 4~20mA two wire system





MAGNETIC LEVEL GAUGE

STANDARD TECHNICAL SPECIFICATIONS

STANDARD TECHNICAL SPECIFICATIONS

Cage	2-3" NB Pipe: SS-316 / 316L / Alloy 625 / Alloy 825 / 904L / UNS – 31254 / MONEL 400 / Titanium / Host C276, other materials
Max Center to Center Distance	60ft. / 18.28m
Max Depth of Top Mounted	20ft. / 6000mm (Style H)
Connecting Flanges	ANSI B16.5
Maximum Viscosity	500 CST
Pressure Rating	200 bar / 3000 psi Maximum
Maximum Operating Temperature	538°C / 1000°F for SS-316 / 316L / Alloy 625 / Alloy 825 / 904L / UNS – 31254 80°C / 176°F for PVDF 40°C / 104°F for PVC
Minimum Specific Gravity of Service Liquid	0.38
Minimum difference in Specific Gravity between Interface Liquid	0.10 (for less than 0.10 consult factory)
Accuracy	±10mm / 3/8"

Note: Refer to transmitter catalog for model selection of magnetostrictive.

ACCESSORIES

I. GRADUATED SCALE

Bliss Anand MLGs are fitted with Stainless Steel scales. The graduation on these can be customized to imperial or metric standards, or any other customer specific requirements.

II. ALARM SWITCH

Magnetically operated Alarm Switches.

- I. Contact Element : Reed Switch
- II. Switch Form : SPDT Hold type
- III. Contact Rating : 1AMP 30V DC & 110/220V AC
- IV. Protection : EExd IIC

Reed level switches can be added to a MLG. These switches, used to sense and/or control high, low, or high/low levels, are activated by the magnet assembly in the float. Just as the MLG float and indicator are magnetically coupled, the float and a magnetic switch couple. When the float moves up or down with the level in the vessel, the float's magnetic field, which extends through the chamber wall, opens or closes a switch.

Since there is no physical contact with the process, magnetic coupling eliminates the need for seals, diaphragms and gaskets common to other level switching devices. Magnetic coupling also eliminates process connections to the switch and therefore no valves are required to block off the switch for maintenance.

Bliss Anand level switches are generally encased in an aluminum or stainless steel enclosure and attached to the outside of the chamber with a clamp which allows for field adjustments. The switch types are electric snap, pneumatic relay or reed.

III. HEAT TRACING

Heat tracing is used to prevent freezing of the liquid, maintain process temperature requirements or keep the process fluid temperature elevated to ensure it does not become viscous. Steam and electric heat tracing are the most common forms.

Many MLGs have steam or electric connections preinstalled to permit easy commissioning in the field or addition of heat tracing at a later date. Steam connections are standard and controlled by thermostatically-operated valves. The two common electric heat tracing configurations are the fixed-point thermostatic switch and the adjustable bulb-type thermostatic switch. Both come with a wiring harness or junction box for field wiring.

Steam is most often selected for heat tracing applications since steam costs less than electricity for equivalent heating. If electric tracing is used, the temperature requirements and the area electrical classification must be specified.

For Bliss Anand MLGs, steam or electric heat tracing is available as a factory-installed option. For MLGs with steam tracing, the unit has two tube connections that are ready for direct connection to the plant steam supply. For MLGs with heat tracing the unit is available with a preinstalled insulation blanket.





MAGNETIC LEVEL GAUGE

ACCESSORIES

IV. INSULATION BLANKETS

Insulation blankets have three parts - the filler, jacket and liner. Insulation is typically a removable blanket for high temperature applications or for freeze protection. The jacket and liners are made of weather resistant silicone cloth and sewn with fire retardant Teflon thread. For cryogenic blankets, the jacket is made of polyurethane and the liner is made of aluminum sheeting.

Insulation blankets are available for every MLG configuration. The insulation blankets may be for high temperatures (up to 1000°F). The blankets have different thickness (0.5-4 inches) based on the required temperature specifications.

Bliss Anand high temperature blankets are made of a needled fiberglass mat. They are attached to the MLG using Velcro® straps. All seams in the insulation and in the jacket are sealed with special vapor barriers to prevent moisture from entering. Quilting pins and cross-stitching ensures blanket integrity.



V. CRYOGENIC INSULATION

To facilitate operation where the product is kept cold via chillers, refrigerants and condensers, cryogenic insulation is provided. By insulating the MLG with a specialized cryogenic jacket, process temperatures can be maintained in the liquid state down to -320°F (-195°C). Acrylic frost extensions are also available which are required for cryogenic units. Cryogenic Insulation is recommended for any gauge that is required to work below a process temperature of 36°F (2°C).



ACCESSORIES

VI. FROST EXTENSION

Bliss Anand offers custom designed frost extensions engineered to specific application requirements. These frost extensions are manufactured of durable acrylic plastic that prevent frost accumulation while ensuring clear visibility to the user and is provided as a standard with all cryogenic insulation.



VII. MAGNETIC TRAPS

Magnetic traps are used to prevent ferromagnetic particles in a vessel from entering the MLG chamber and interfering with the movement of the float. The trap is installed at the bottom process connection. The permanent magnet in the trap ensures the clean and effective removal of ferrous contaminating materials. Several designs are available, each to operate within specific process requirements.

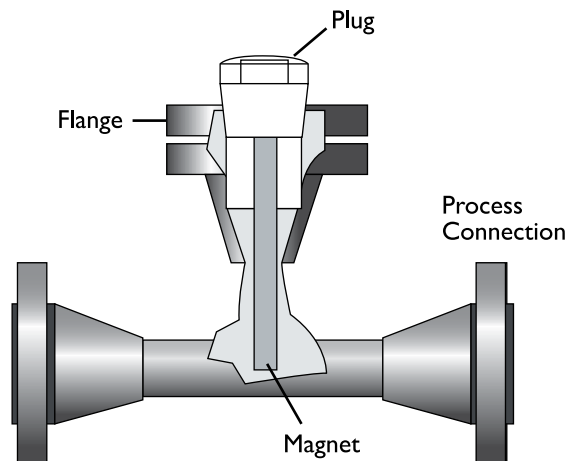



MAGNETIC LEVEL GAUGE

SPECIAL REQUIREMENTS & TESTING

SPECIAL REQUIREMENTS & TESTING

- Hydrotesting
- PMI
- D.P. Test
- Radiography
- Ultra Sonic
- PWHT
- Approved Weld Procedures & Welder Certifications
- Nace Compliance
- HIC Compliance
- SP Alloy Weldings (Alloy 825, Stainless Steel, Monel, LF2 etc)
- Other testing available as required



ENGINEERING STANDARDS

- PED 97/23/EC (Pressure equipment)
- ASME Section VIII-Div. I (Pressure Vessel – unfired)
- ASME B 31.1-2008 (Power Piping)
- ASME B 31.3-2008 (Process Piping)
- ASME Section II (Material Specification)
- ASME Section IX (Welding procedures)
- ASME Section V (Non-Destructive Examination)
- ASME B16.5-2009 (Flanges & fittings)
- ASME B16.9 (Reducers & End Caps)
- And all major applicable standards for castings, forgings, pipes, bars, sheets etc. as per ASTM/ASME standard latest versions.





BLISS ANAND

16-002/BA

Manufacturing Unit:

AMERICAS

Bliss Anand America LLC
3400 Awesome Lane, La Porte,
Texas - 77571, USA
Ph: +1 (281) 479-BLIS (2547)
Fax: +1 (281) 542-7000
e-mail: sales@blissanandusa.com

MIDDLE EAST

Global Engg. Solutions FZCO
(A 100% Subsidiary of Bliss Anand)
RA 08, FG 01, P.O. Box 18576,
Jebel Ali Free Zone, Dubai, U.A.E.
Ph: +971-4-883-5633
Fax: +971-4-883-5644
e-mail: gages@eim.ae

ASIA

Bliss Anand Pvt. Ltd.
Plot # 240, Sector-3,
Growth Center, HSIIDC, Bawal,
Haryana-123501, India
Ph: +91-1284-269400-99
Fax: +91-124-2290884
e-mail: sales@blissanand.com

USA | CANADA | SOUTH AMERICA | MIDDLE EAST | SAUDI ARABIA | ASIA

BLISS ANAND: *The spirit to walk an extra mile*

Worldwide: www.blissanand.com