



BLISS ANAND

Gauge Valve







Gauge Valve

Index: Gauge Valve

Gauge Valve	3
Series 10	4
Series 20	5
Series 40	6
Series 80	7-9
Tank Connection Options	10
Gauge - Valve Combinations & Minimum C.C. Distance	11
Notes	12-13



GAUGE VALVE



VALVE OPTIONS

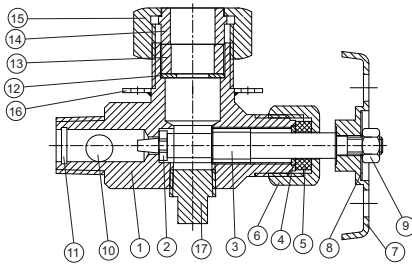

SERIES - '10'

100LBS@100 DEG F

BLISS ANAND 10-TU valves feature straight type body with integrated seat and Elastomer (EPDM) Glass tube packing bush, with integral seat and PTFE valve cone. These are primarily used for tubular type level gages for low pressure & temperature applications. They are equipped with mounting clamps to fit glass protection rods. They also features a ball check arrangement.

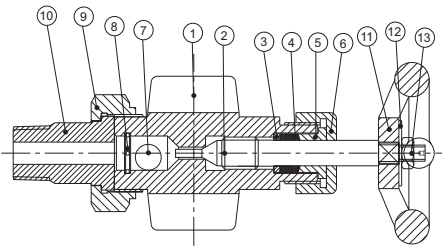

SERIES - '20'

2400 LBS @ 100°F, 1400 LBS @ 750°F

BLISS ANAND SERIES 20 valves features integrated of bonnet drop forged offset steel bodies, stainless steel trim with wide choice of connections. Their design incorporate ball check arrangements and union gauge connections. They are equipped with union gauge connections which permits simple installation and easy access to the ball check.

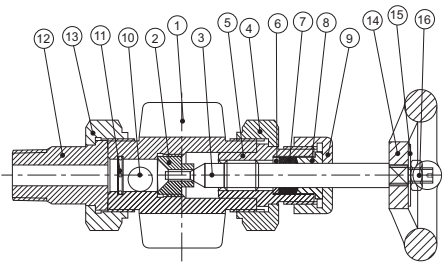

SERIES - '40'

4000 LBS @ 100°F, 1500 LBS @ 750°F

BLISS ANAND SERIES 40 valves are designed and built to the highest standard quality features such as regrindable and renewable seat and complete rust proofed carbon steel parts assuring long trouble free services union gauge connection enables gauges to be turned to any desired angle and removed of gauge without disturbing the valve which saves time in maintenance. Also the valve features union bonnet, and stem back seating.

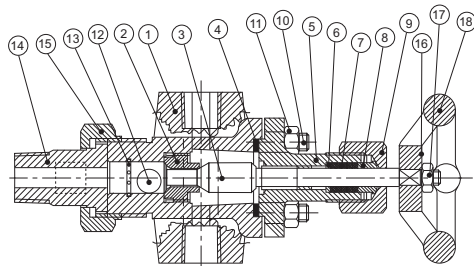

SERIES - '80'

4000 LBS @ 100°F, 1500 LBS @ 750°F

BLISS ANAND SERIES 80 valves are designed with bolted bonnet construction. Valves are equipped with stainless steel ball checks, stem back seating and offset construction. Union gauges connections is optional.



SERIES 10

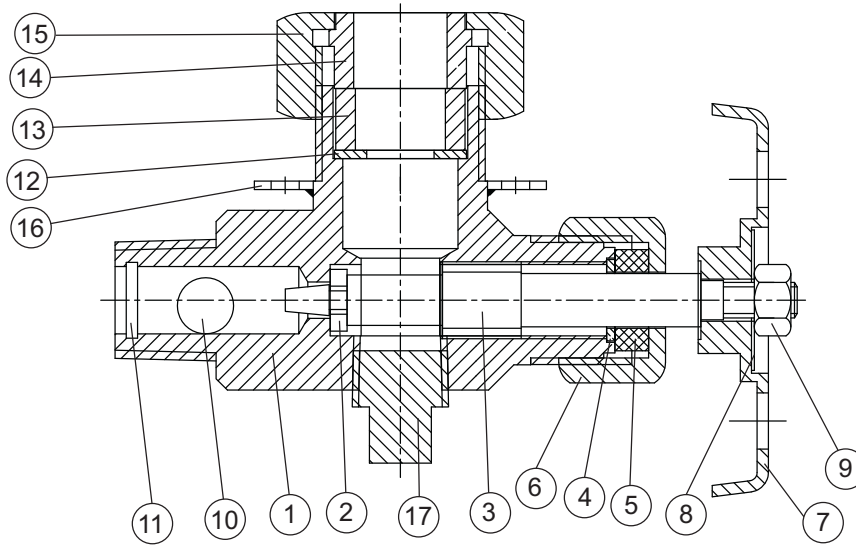

PART NO.	PART NAME	STD MATERIAL	PART NO.	PART NAME	STD MATERIAL
1	VALVE BODY	A-105	10	BALL CHECK	SS-316
2	VALVE WASHER	TEFLON	11	BALL CHECK STOP	SS-304
3	STEM	SS-304	12	WASHER	SS-304
4	STEM PACKING WASHER	SS-316	13	GLASS PACKING	EPDM
5	STEM PACKING	GRAFOIL	14	PACKING GLAND	STEEL
6	PACKING NUT	STEEL	15	GLASS PACKING NUT	STEEL
7	HANDWHEEL	ZINC	16	MOUNTING CLAMP	STEEL
8	TAG NAME PLATE	SS-304	17	PLUG	STEEL
9	STEM NUT	STEEL			

STANDARD FEATURES

SOFT SEAT VALVE CONE:

The valve features a soft seating valve cone in PTFE capped at the stem tip. This ensures zero leak when closed

STRAIGHT BODY PATTERN:

The valve features a straight body pattern

Standard Connections:

Vessel : 3/4" NPT male
 Drain : 3/4" NPT female
 Gauge : 3/8" NPT female

Optional Connections:

Vessel : 1/2" NPT male
 Vent & Drain : 1/4" NPT plugged

Safety Shut OFF:

Valves are provided with stainless steel ball check which instantaneously shuts off flow of the medium being gauged in the event of glass breakage

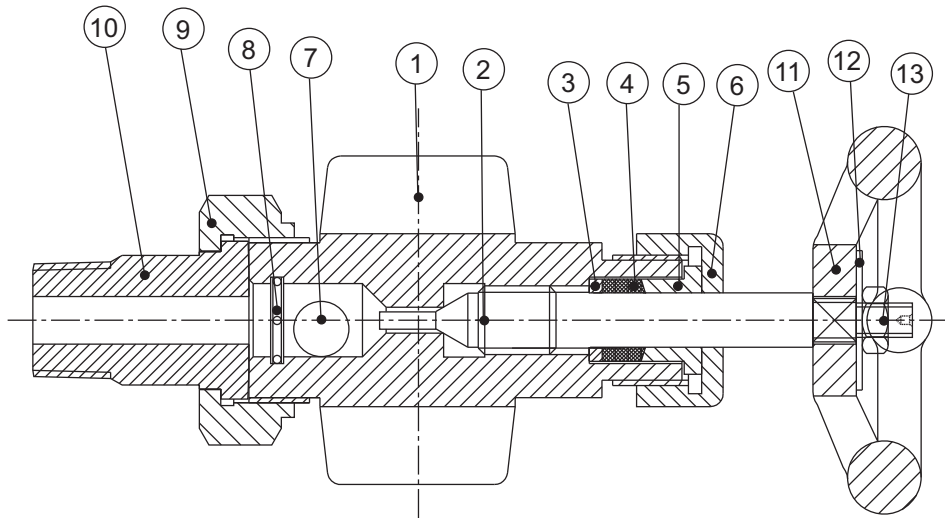

PART NO.	PART NAME	STD MATERIAL
1	VALVE BODY	A-105 / F-316L
2	SPINDLE	SS-316L
3	GLAND STOPPER	SS-316
4	PACKING RING	GRAPHITE
5	GLAND FOLLOWER	SS-316
6	GLAND NUT	STEEL
7	BALL	SS-316

PART NO.	PART NAME	STD MATERIAL
8	BALL STOPPER	SS-304
9	TAIL PIECE	STEEL
10	UNION NUT	STEEL
11	HAND WHEEL	WCB
12	NAME PLATE	SS-304
13	HAND WHEEL NUT	STEEL

STANDARD FEATURES

BACKSEATING STEM:

When the valve is opened to its limit, the stem seats against the bonnet allowing the valve to be repacked while under pressure.

STRAIGHT BODY PATTERN:

The straight body is of a straight forward angle pattern, with the gauge, drain and vessel connections on intersecting centrelines.

OFFSET BODY PATTERN:

The Offset body is an angle pattern valve, with the centreline of the gauge and drain connections offset 22mm from the centreline of the vessel connections, Hence by removing the vent/Drain plugs, the interior of a top and bottom connected gauge glass may be cleaned without removing the gauge.

UNION GAUGE CONNECTION:

Both the straight and the offset can be furnished with a union gauge connection which allows a top and bottom connected gauge to be turned to any desired angle for convenient visibility. It also makes possible the removal of the gauge without removing the valves, a feature which saves time when the gauges must be cleaned or serviced.

Standard Connections:

- Vessel : 3/4" NPT male
- Drain : 1/2" NPT female
- Gauge : 1/2" NPT female

Optional Connections:

- Vessel : 1/2" NPT male or 3/4" NPT male for socket weld or flanged to suit requirements.
Series 80 valves can be supplied with ANSI 150, 300 or 600 integral flanges.
- Gauges : On union connected valves 1/2" NPT male or 3/4" NPT male. On all valves 3/4" NPT female screwed and 1/2" or 3/4" female socket weld recess.
- Vent/Drain : 3/4" NPT female screwed and 1/2" or 3/4" female socket weld recess.
vent & drain valves on request.

Connections are also available screwed.

Safety Shut Off:

Valves may be provided with stainless steel ballcheck which instantaneously shuts off flow of the medium being gauged in the event of glass breakage. The ball operates upstream from the seat and can be furnished for vacuum seating if required.



SERIES 40

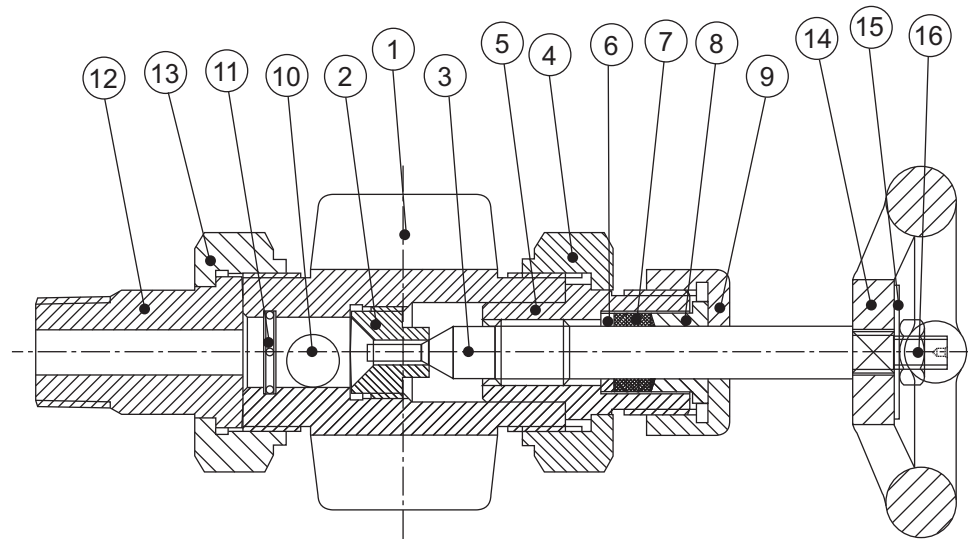

PART NO.	PART NAME	STD MATERIAL	PART NO.	PART NAME	STD MATERIAL
1	VALVE BODY	A-105 / F-316L	9	GLAND NUT	STEEL
2	RENEWABLE SEAT	SS-316	10	BALL	SS-316
3	SPINDLE	SS-316L	11	BALL STOPPER	SS-304
4	BONNET NUT	STEEL	12	TAIL PIECE	STEEL
5	BONNET	STEEL	13	UNION NUT	STEEL
6	GLAND STOPPER	SS-316	14	HAND WHEEL	WCB
7	PACKING RING	GRAPHITE	15	NAME PLATE	SS-304
8	GLAND FOLLOWER	SS-316	16	HAND WHEEL NUT	STEEL

STANDARD FEATURES

BACKSEATING STEM:

When the valve is opened to its limit, the stem seats against the bonnet allowing the valve to be repacked while under pressure.

STRAIGHT BODY PATTERN:

The straight body is of a straight forward angle pattern, with the gauge, drain and vessel connections on intersecting centrelines.

OFFSET BODY PATTERN:

The Offset body is an angle pattern valve, with the centreline of the gauge and drain connections offset 22mm from the centreline of the vessel connections, Hence by removing the vent/Drain plugs, the interior of a top and bottom connected gauge glass may be cleaned without removing the gauge.

UNION GAUGE CONNECTION:

Both the straight and the offset can be furnished with a union gauge connection which allows a top and bottom connected gauge to be turned to any desired angle for convenient visibility. It also makes possible the removal of the gauge without removing the valves, a feature which saves time when the gauges must be cleaned or serviced.

Standard Connections:

Vessel : 3/4" NPT male
 Drain : 1/2" NPT female
 Gauge : 1/2" NPT female

Optional Connections:

Vessel : 1/2" NPT male or 3/4" NPT male for socket weld or flanged to suit requirements.
 Series 80 valves can be supplied with ANSI 150, 300 or 600 integral flanges.

Gauges : On union connected valves 1/2" NPT male or 3/4" NPT male. On all valves 3/4" NPT female screwed and 1/2" or 3/4" female socket weld recess.

Vent/Drain : 3/4" NPT female screwed and 1/2" or 3/4" female socket weld recess.
 vent & drain valves on request.

Connections are also available screwed.

Safety Shut Off:

Valves may be provided with stainless steel ballcheck which instantaneously shuts off flow of the medium being gauged in the event of glass breakage. The ball operates upstream from the seat and can be furnished for vacuum seating if required.

SERIES 80



GAUGE VALVES

Gauge Valves With Bolted and Bonnet & Inside Screw, Designed to Reduce Threaded Connections.

These rugged valves are designed and manufactured for use with flat glass gauges, instruments piping and other applications.

Pressure Rating per intermediate rating ANSI 1250

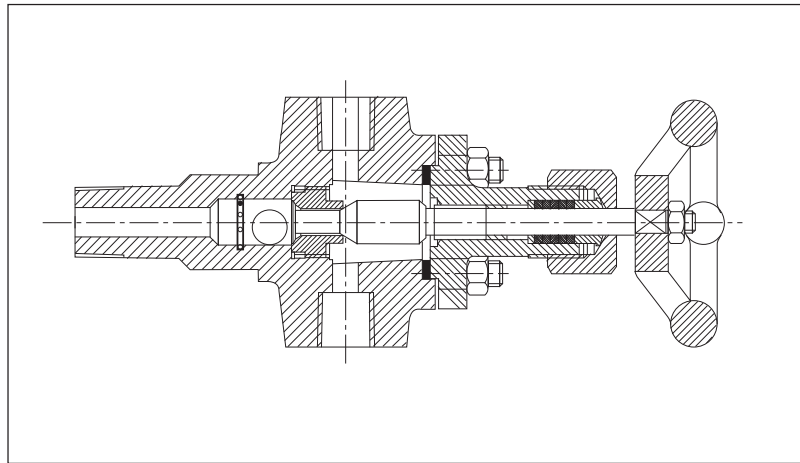

83 STRAIGHT PATTERN WITH FEMALE NPT GAUGE CONNECTION, MALE VESSEL CONNECTION ON SOLID SHANK

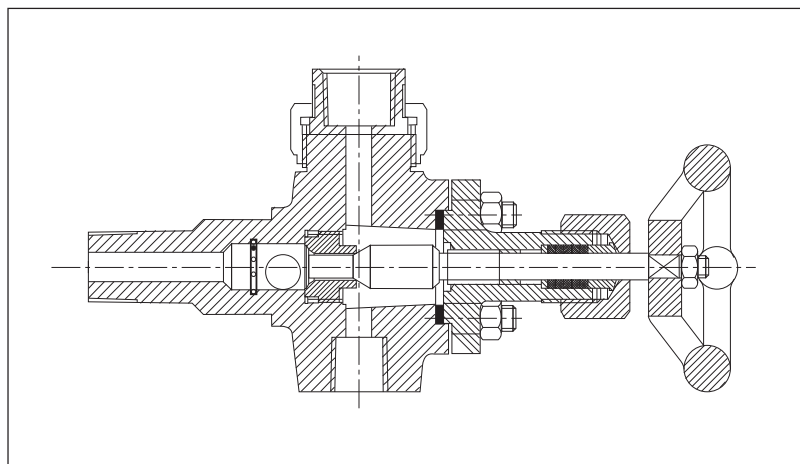

84 STRAIGHT PATTERN WITH FEMALE NPT UNION GAUGE CONNECTION, MALE VESSEL CONNECTION ON SOLID SHANK



SERIES 80

GAUGE VALVES

Gauge Valves With Bolted and Bonnet & Inside Screw, Designed to Reduce Threaded Connections.

These rugged valves are designed and manufactured for use with flat glass gauges, instruments piping and other applications.

Pressure Rating per intermediate rating ANSI 1250

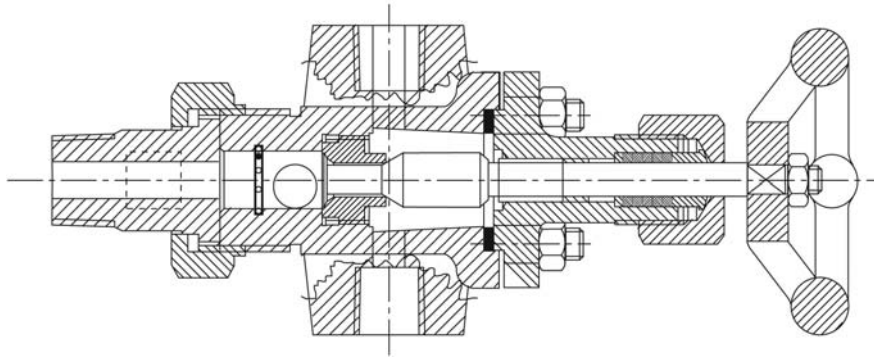

86 OFFSET PATTERN WITH FEMALE NPT GAUGE CONNECTION,
MALE UNION VESSEL CONNECTION

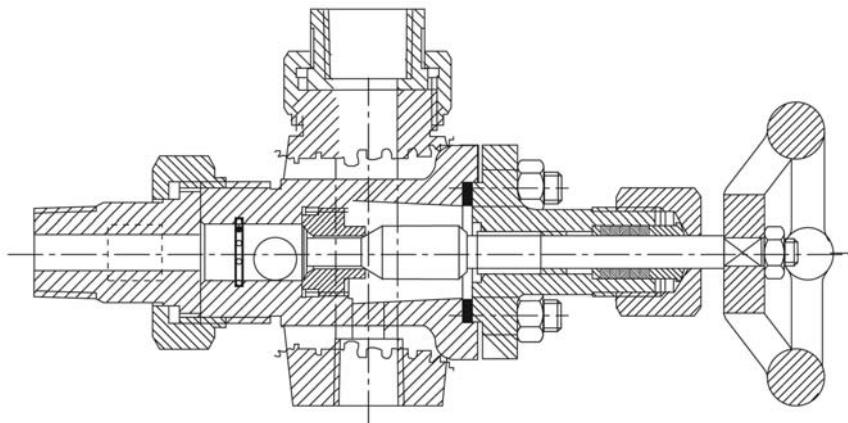

87 OFFSET PATTERN WITH FEMALE NPT UNION GAUGE
CONNECTION, MALE UNION VESSEL CONNECTION

SERIES 80

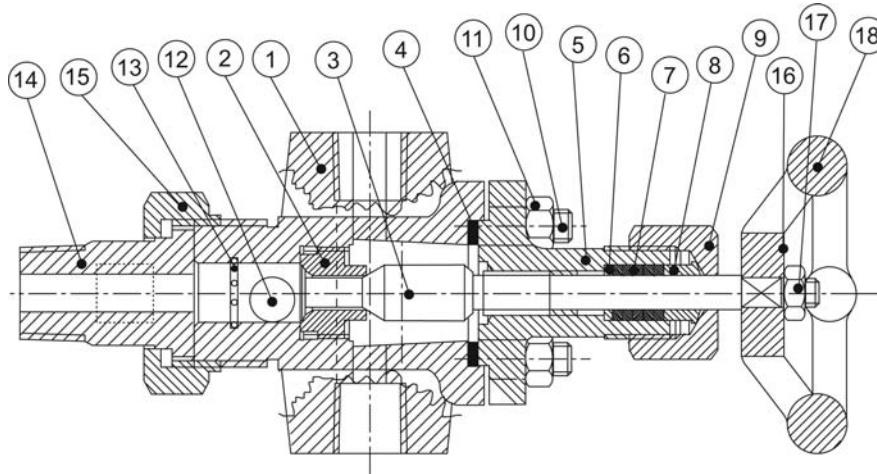

PART NO.	PART NAME	STD MATERIAL
1	VALVE BODY	A-105 / F-316L
2	RENEWABLE SEAT	SS-316
3	SPINDLE	SS-316L
4	BONNET GASKET	SP WOUND SS 316+ GRAFOIL
5	BONNET	A-105/ F-316L
6	GLAND STOPPER	SS-316
7	PACKING RING	GRAPHITE
8	GLAND FOLLOWER	SS-316
9	GLAND NUT	STEEL

PART NO.	PART NAME	STD MATERIAL
10	BONNET STUD	A-193 GR. B7
11	BONNET NUT	A-194 GR. 2H
12	BALL	SS 316
13	BALL STOPPER	SS 304
14	TAIL PIECE	STEEL
15	UNION NUT	STEEL
16	HAND WHEEL	WCB
17	NAME PLATE	SS 304
18	HAND WHEEL NUT	STEEL

STANDARD FEATURES

BACKSEATING STEM:

When the valve is opened to its limit, the stem seats against the bonnet allowing the valve to be repacked while under pressure.

STRAIGHT BODY PATTERN:

The straight body is of a straight forward angle pattern, with the gauge, drain and vessel connections on intersecting centrelines.

OFFSET BODY PATTERN:

The Offset body is an angle pattern valve, with the centreline of the gauge and drain connections offset 22mm from the centreline of the vessel connections. Hence by removing the vent/drain plugs, the interior of a top and bottom connected gauge glass may be cleaned without removing the gauge.

UNION GAUGE CONNECTION:

Both the straight and the offset can be furnished with a union gauge connection which allows a top and bottom connected gauge to be turned to any desired angle for convenient visibility. It also makes possible the removal of the gauge without removing the valves, a feature which saves time when the gauges must be cleaned or serviced.

Standard Connections:

Vessel : 3/4" NPT male
 Drain : 1/2" NPT female
 Gauge : 1/2" NPT female

Optional Connections:

Vessel : 1/2" NPT male or 3/4" NPT male for socket weld or flanged to suit requirements.
 Series 80 valves can be supplied with ANSI 150, 300 or 600 integral flanges.

Gauges : On union connected valves 1/2" NPT male or 3/4" NPT male. On all valves 3/4" NPT female screwed and 1/2" or 3/4" female socket weld recess.

Vent/Drain : 3/4" NPT female screwed and 1/2" or 3/4" female socket weld recess.
 vent & drain valves on request.

Connections are also available screwed.

Safety Shut Off:

Valves may be provided with stainless steel ballcheck which instantaneously shuts off flow of the medium being gauged in the event of glass breakage. The ball operates upstream from the seat and can be furnished for vacuum seating if required.



GAUGE VALVE

TANK CONNECTION OPTIONS

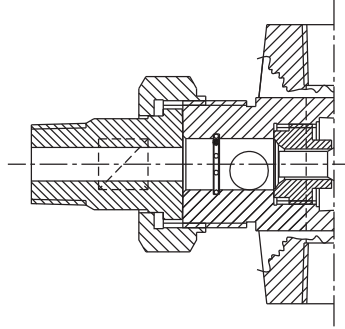

PLAIN UNION (M)

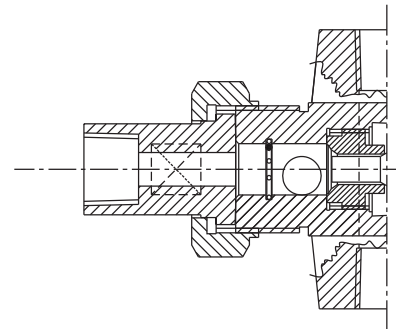

PLAIN UNION (F)

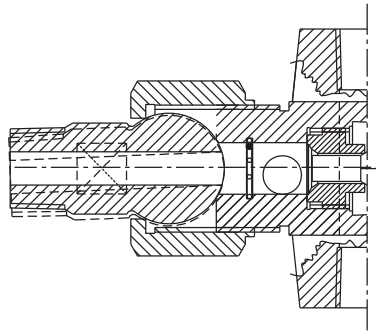

SPHERICAL UNION (M)

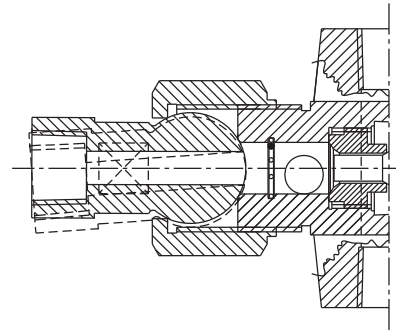

SPHERICAL UNION (F)

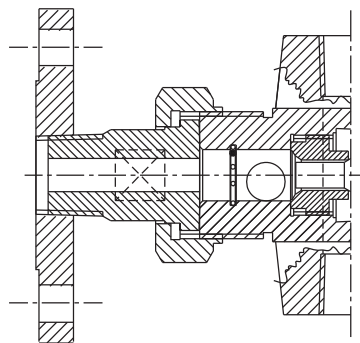

FLANGE PLAIN UNION (M)

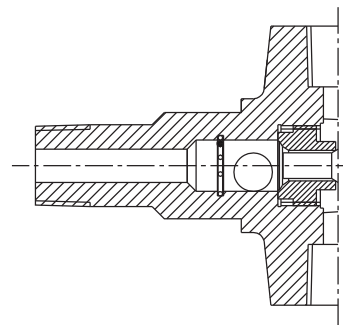

SOLID SHANK (M)

Liquid Level Gauges and Valves Minimum Vessel Centres *(All dimensions in mm)* and Gauge-Valve Combinations



Note: Standard connections are NPT female screwed on gauges and valves with assembling made using SCH 160 Male threaded adaptors. Other connection options are available including male and female unions, socket welds, flanges etc, however centres dimensions are subject to confirmation by Bliss Anand.

Connection		End /Top & Bottom										Side/Side					
Series		TL & RL		TM & RM				TH		RH		TL, RL, TM, RM, TH/RH					
Gauge Conn Size		1/2" & 3/4"		1/2"		3/4"		1/2"		3/4"		1/2"			3/4"		
Size No	Visible Length	86	87	86	87	86	87	86	87	86	87	In Line	Offset In Side	Offset Out Side	In Line	Offset In Side	Offset Out Side
												83	86	87	83	86	87
11	95	248	308	222	283	235	295	254	314	235	295	133	89	178	143	98	187
12	121	273	333	248	308	260	321	279	340	260	321	159	114	203	168	124	213
13	146	298	359	273	333	286	346	305	365	286	346	184	140	229	194	149	238
14	171	324	384	298	359	311	372	330	391	311	372	210	165	254	219	175	254
15	200	352	413	327	387	340	400	359	419	340	400	238	194	283	248	203	292
16	232	384	445	359	419	371	432	391	451	371	432	270	225	314	279	235	324
17	260	413	467	387	448	400	460	419	479	400	460	298	254	343	308	264	352
18	302	454	514	429	489	441	502	460	521	441	502	340	295	384	349	305	394
19	321	473	533	448	508	460	521	479	540	460	521	359	314	403	368	324	413
23	330	483	543	457	518	470	530	489	549	470	530	368	324	413	378	333	422
24	381	533	594	508	568	521	581	540	600	521	581	419	375	464	429	384	473
25	438	591	651	565	625	578	638	597	657	578	638	476	432	521	486	441	530
26	502	654	714	629	689	641	702	660	721	641	702	540	495	584	549	505	594
27	559	711	772	686	746	699	759	718	778	699	759	597	552	641	606	562	651
28	641	794	848	768	829	781	840	800	860	781	840	679	635	724	689	645	733
29	679	832	892	806	867	819	879	838	899	819	879	718	673	762	727	683	772
36	772	924	984	899	959	911	972	930	991	911	972	810	765	854	819	775	864
37	857	1010	1070	984	1045	997	1057	1016	1076	997	1057	895	851	940	905	860	949
38	981	1133	1194	1108	1168	1121	1181	1140	1200	1121	1181	1019	975	1064	1029	984	1073
39	1038	1191	1251	1165	1226	1178	1238	1197	1257	1178	1238	1076	1032	1121	1086	1041	1130
47	1156	1308	1368	1283	1343	1295	1356	1314	1375	1295	1356	1194	1149	1238	1203	1159	1248
48	1321	1473	1534	1448	1508	1461	1521	1480	1540	1461	1521	1359	1314	1403	1368	1324	1413
49	1397	1549	1610	1524	1584	1537	1597	1556	1616	1537	1597	1435	1391	1480	1445	1400	1489
57	1454	1607	1667	1581	1641	1594	1654	1613	1673	1594	1654	1492	1448	1538	1502	1457	1546
58	1661	1813	1873	1788	1848	1800	1861	1819	1880	1800	1861	1699	1654	1743	1708	1664	1753
59	1756	1908	1969	1883	1943	1895	1956	1915	1975	1895	1956	1794	1749	1838	1803	1759	1848
68	2000	2153	2213	2127	2188	2140	2200	2159	2219	2140	2200	2038	1994	2083	2048	2003	2092
69	2115	2267	2327	2242	2302	2254	2315	2273	2334	2254	2315	2153	2108	2197	2162	2118	2207
78	2340	2492	2553	2467	2527	2480	2540	2499	2559	2480	2540	2378	2334	2423	2388	2343	2432
79	2473	2626	2686	2600	2661	2613	2673	2632	2692	2613	2673	2511	2467	2556	2521	2477	2565
88	2680	2832	2892	2807	2867	2819	2880	2838	2899	2819	2880	2718	2673	2762	2727	2683	2772
89	2832	2985	3045	2959	3019	2972	3032	2991	3051	2972	3032	2870	2826	2915	2880	2835	2924
98	3019	3172	3232	3146	3207	3159	3219	3178	3239	3159	3219	3058	3013	3102	3067	3023	3112
99	3191	3343	3404	3318	3378	3331	3391	3350	3410	3331	3391	3229	3185	3273	3239	3194	3283

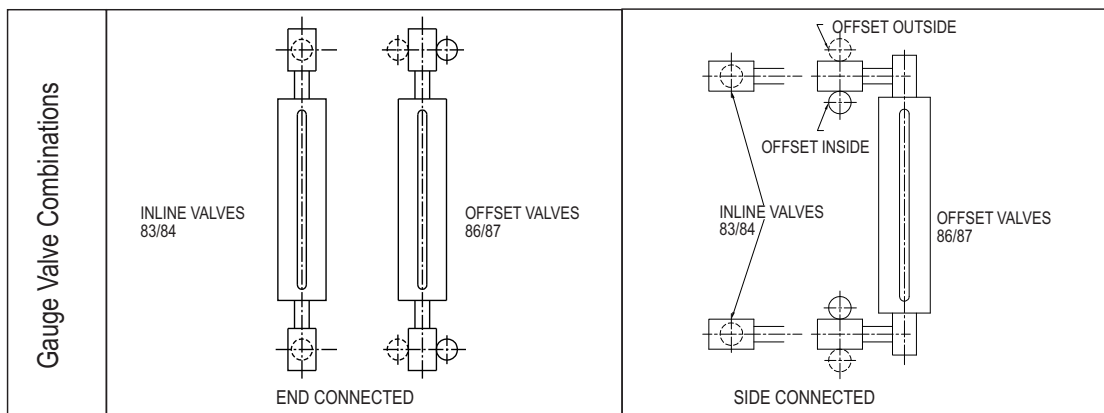





BLISS ANAND

Manufacturing Units:

AMERICAS

Bliss Anand, America
6614, Bourgeois Road, Houston,
Texas-77066
Ph. : (281) 537-7859, 537-7813
Fax: (281) 537-7033
e-mail : sales.usa@blissanand.com
sales@blissanandusa.com

MIDDLE EAST

GLOBAL ENGG. SOLUTION FZCO
(A 100% Subsidiary of BLISS ANAND-INDIA)
P. O. Box: 18576, RA 08, WF 04,
Jebel Ali Free Zone, Dubai, U.A.E.
Ph. : +971-4-883 56 33
Fax : + 971-4-883 56 44
e-mail : gages@eim.ae

ASIA

Bliss Anand Pvt. Ltd.
92 B & 93 B, Sector - 5,
IMT Manesar, Gurgaon,
Haryana-122 050 (INDIA)
Ph. : + 91 124-4366000-09 (10 Lines)
Fax : + 91 124-2290884
e-mail : sales@blissanand.com

HOUSTON

DUBAI

KAZAKHSTAN

THAILAND

CANADA

INDIA

BLISS ANAND: *The spirit to walk an extra mile*

Worldwide: www.blissanand.com

#13-019-BA